

ECO4 SUPERIOR PRODUCTS: DUAL POWERED LOCOMOTIVES ALP-45DP FOR THE NORTH AMERICAN RAILWAYS

Diego CANETTA, Project Engineer Manager, Bombardier Transportation Italy

Dr. Urs BIKLE, Vice President Engineering, Bombardier Transportation Switzerland

ABSTRACT

Dual Powered locomotives running both in electric and diesel-electric traction are particularly designed for service in combined traffic such as in large North-American cities and their neighbourhood. Dual Powered locomotives present a special challenge to fit all the high power equipment into a 4 axle locomotive with axle load restrictions of about 30 t / axle. The presented concept contains an electric traction chain on the basis of most modern locomotives and a diesel traction chain consisting of 2 diesel engines equipped back to back to the converter cubicle and operating in 2 independent diesel-electric circuits. To achieve the needed schedule adherence special design and control solutions are applied to reach the requested tractive efforts under all circumstances and to optimize the transition between electric and diesel-electric configurations.

Special care is given to economic, environmentally friendly solutions and control concepts, e.g. designs to achieve low emissions & fuel consumption, low losses, use of specific material, minimized track forces, optimized HVAC control and many more.

Keywords: Dual Powered locomotive, Diesel-electric locomotive, Electric locomotive, environmentally friendly railway solutions, eco4

INTRODUCTION

In the program **eco⁴** Bombardier Transportation balances Energy, Efficiency, Economy and Ecology with convincing and reliable solutions, services and products. Dual Powered locomotives combining both electric and diesel-electric traction are an interesting member of the **eco⁴** portfolio for use especially in the North American railway network, which is characterized by many freight lines for diesel traction and just a few electrified lines for passenger traffic. In partnership with 2 major railway operators in North America, New Jersey Transit (NJT) and Agence Métropolitaine de Transport de Montréal (AMT), Bombardier Transportation is developing locomotives to run both under electric catenaries and powered by diesel engines. This will give the operators the opportunity to perform so called “one-seat-

Dual Powered locomotive
CANETTA, Diego; BIKLE, Urs Dr.

rides” that prevent the huge amount of passengers from changing trains at the system borders of their wide networks.

The locomotives are designed for use in passenger traffic both where electrical power is available and where catenaries do not exist and will contribute to optimized operation concepts. The design is based on the very energy and noise efficient traction concepts of the European TRAXX locomotives and can also be transferred to European applications.

Main requirements by the North American operators are as follows:

Electric operation: 25 kV 60 Hz and 12 kV 25 Hz

Maximum speed in electric operation: 125 mph (200 km/h)

Maximum speed in Diesel operation: 100 mph (160 km/h)

Max weight: 130.64 t

Maximum axle load: 32.66 t

Power at wheels (electric): 4000 kW (4.4 MW peak power)

Installed Diesel Power: 2*1567 kW

Head end power (HEP): 1100 kVA

Starting tractive effort: 316 kN

Design life: minimum 30 years

This single cab loco will be used with Bi/Multi level cars in North America on some of the busiest lines in the world. NJT is carrying 251 million people (73 on rail) and schedule adherence is a key for success, particularly in the traffic to Manhattan through the Trans Hudson express tunnel. For this reason reliability and clever transitions between the electric and the diesel-electric power systems are key requirements. NJT will operate the trains with 14 vehicles including locomotives in push-pull operation at one or both ends.



Figure – Dual Powered locomotive in NJT and AMT configuration

Special care is given to the ambient conditions that are particularly severe for the requested service where the loco will face rigid Canadian winter as well as high temperatures in New York Penn station:

12th WCTR, July 11-15, 2010 – Lisbon, Portugal

Operating ambient temperatures: - 40°C ... + 60°C

The project definition phase started in 2006 and initial orders were placed in August 2008. After the successfully completed concept phase the detailed design is ongoing on schedule, which will be followed in 2010 by the start of dynamic testing.

In line with its **eco⁺** philosophy, Bombardier is developing the project with high attention to the environment by choice of eco-compatible material, energy efficient solutions and optimized emission levels in the different operation points.

GENERAL DESCRIPTION

The Dual Powered locomotive combines high power diesel locomotives' with electric locomotives' requirements. As such, a Dual Powered locomotive brings significant benefits to fleet operation. With design teams experienced in such unique product development Bombardier Transportation focused its efforts to several key concepts that contribute to meeting the needs and expectations of both NJT and AMT.

The locomotive concept has been developed for the special needs of commuter railways, considering in particular

Short distances between stations

High acceleration capability hauling heavy trains

Maximum tractive effort can be used under all conditions due to the moderate adhesion coefficient of 0.25 only

Sufficient Head End Power (HEP)

Long periods of standstill with HEP operation only

High reliability and redundancy offering a high level of fire safety

Optimized fuel consumption to improve economics and to minimize environmental impact

Low unsprung masses to minimize wheel-track forces

The Dual Powered locomotive for North America ALP-45DP (American Locomotive Passenger, 4 axles, 5 MW transformer design power) is based on the existing ALP-46 locomotives of NJT's fleet.

Several components in the design philosophy, as well as many small parts and methods employed are identical. This considerably optimizes the operational costs such as spare parts stock, training, maintenance & management and minimizes risks as these components and methods are already proven in the same environment.

The locomotive contains:

Two medium size high speed diesel engines instead of one large and heavy medium speed prime mover, as commonly used in North America. The two engines are located in completely separate engine compartments using separate cooling and fuel systems. The selected diesel concept is beneficial in several major aspects:

During standstill or while moving slowly one engine can be shut down, which saves fuel and increases engine life time (by reduction of engine operation hours).

When standing in HEP operation only or while moving slowly in shunting mode one small engine operates in a more efficient load cycle. This saves fuel and avoids engine problems caused by low power operation. It is not only leading to a reduction of noise and pollution in yards, but thanks to the fuel savings the tank capacity can be designed to a smaller total volume saving weight. In case of a failure in one of the engine systems the locomotive can still operate with the other engine (half power/full starting tractive effort) lowering the risk of train breakdowns. As the two engine systems including the fuel tanks are completely separated from each other, the fire load as well as the risk of spilling fuel in case of an accident is lower compared to a single engine concept. Last but not least 2 small high speed engines are accelerating faster than one, hence can reduce travelling time (engine acceleration 100 rpm/s, which means approximately 10 s from idle or HEP load speed to full speed).

The proposed design allows the installation of high power capacity in electric operational mode, as well as in diesel operation mode. The total installed diesel power of 3134 kW (4200 hp) is similar to the power of typical high power diesel locomotives for passenger service resulting in 2.7 MW wheel power without HEP. The electrical power is 4 MW at the wheel rim. In case of moderate cooling temperature and low HEP power (< 400 kVA), the peak power capacity in electrical operation is 4400 kW at the wheel rim (see figure 1). The locomotive's bogies are also based on the ALP-46 concept while being reinforced to cope with the higher axle loads.

OVERALL VEHICLE CONFIGURATION

The overall configuration of the locomotive can be summarized as follows:

Streamlined single cab monocoque carbody with removable roof sections, supporting equipment as the cooling radiators, the air ducts and the pantograph.

Discrete machinery compartments, separated by walls (starting from the cab):

Dual Powered locomotive
CANETTA, Diego; BIKLE, Urs Dr.

Air intake truck #1, signalling equipment.

Engine #1 with alternator, and cooling system installed on the roof section located above.

Converter with integrated high voltage and auxiliary rack and HEP distribution.

Engine #2 with alternator, and cooling system installed on the roof section located above.

Rear compartment containing air intake for truck#2, battery box, low voltage rack, brake resistor and toilet.

Transformer located under-floor in the centre of the locomotive.

Two separate fuel tanks, integrated in the carbody structure.

Side aisles combined with centre aisles, one wide throughway.

The Dual Powered locomotive carbody is a fully welded structure (monocoque type), very similar to the existing NJT's ALP-46 locomotive carbody. The structural design is based on the existing FRA approved above mentioned carbody design. The main differences are: An extended carbody length (+ 2.5m / 8' 2 ½"), reinforcement of the longitudinal structural members due to the higher weight and replacement of the rear cab with a rear wall structure.

Main subcomponents of the welded structure are:

Front and rear headstocks, similar to ALP-46

Front and rear truck suspension transoms

Front and rear fuel tanks with integrated traction rod pivot and transformer transom

Main longitudinal structural members

Front operator's cab structure, similar to the ALP-46 with the exception of roof structure and anti climber design improvements.

Side and rear walls

The roof sections are easily removable, similar to ALP-46 arrangement. Bolted crossbeams are installed between the roof sections.

Dual Powered locomotive
CANETTA, Diego; BIKLE, Urs Dr.

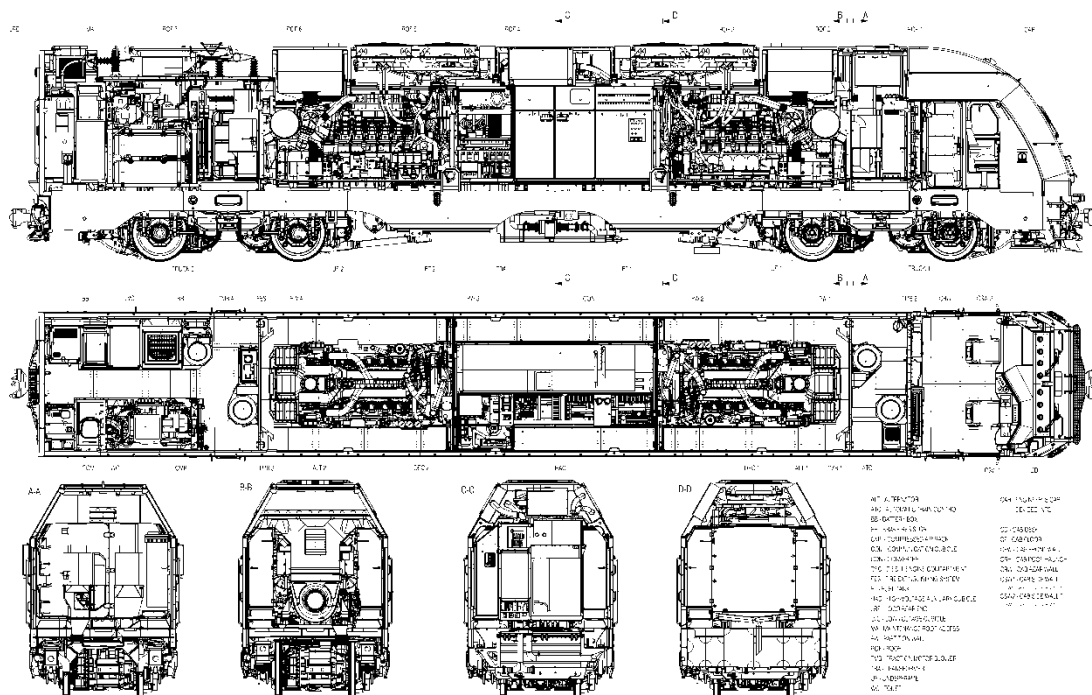

Figure - Configuration of the Dual Powered locomotive

Bogie

The design of the bogie is based on the well proven design of the ALP-46 bogie, with modifications in the axle size and other components resulting through the increased axle load, in the suspension of the drive unit and in the additional tread brake.

The truck also includes all features required for high speed operation and low dynamic wheel to rail forces:

Low unsuspended mass: As the drive units and brake components are fully suspended the vertical dynamic forces are low.

Laterally suspended axles keep the lateral forces low.

Soft vertical and lateral secondary suspension provides low lateral and vertical forces for excellent ride quality.

The traction rod minimizes the load transfer between the axles.

The drive unit including the disk brake arrangement is identical to the ALP-46 locomotive with modifications in the support. The running stability of the truck will not decrease by the introduced changes, since the wheelbase is increased from 104.3 inch (2650 mm) to 110.2 inch (2800 mm).

The bogie frame is a welded construction with high strength to withstand the static and dynamic loads being validated by both finite element stress calculations as well as fatigue tests.

Mainly, the frame consists of two longitudinal beams, two end transoms and a centre transom. One end transom carries the pivot for the traction rod.

Primary and secondary suspension are provided by coil springs. Vertical and lateral hydraulic dampers as well as yaw dampers are acting parallel to the secondary suspension. Two vertical dampers are installed at each axle box. These dampers are a special design to support the wheel sets when lifting the truck. It is foreseen to use a pendulum similar as in the ALP-46 locomotive as a lifting device for the bogie.

Auxiliary Power and Battery Charger/Batteries

Three-phase On-board Power Supply

The auxiliary inverter is integrated into the traction converter, both operating in similar modes.

In compliance with the specification to increase the locomotive's mission reliability and in order to obtain a high availability, two identical auxiliary inverters are installed. One of the 2 provides a constant 3-phase 480V/60 Hz voltage to the three-phase trainline (HEP) as well as to some locomotive loads, while the other one (AUX) supplies a variable frequency 3-phase voltage (up to 60 Hz) to the traction motor blowers and cooling towers in order to adapt the cooling power to the actual needs.

The concept of both auxiliary inverters is identical to the traction inverters while the three-phase transformers (HEP and AUX) are each adapted to the specific power requirements.

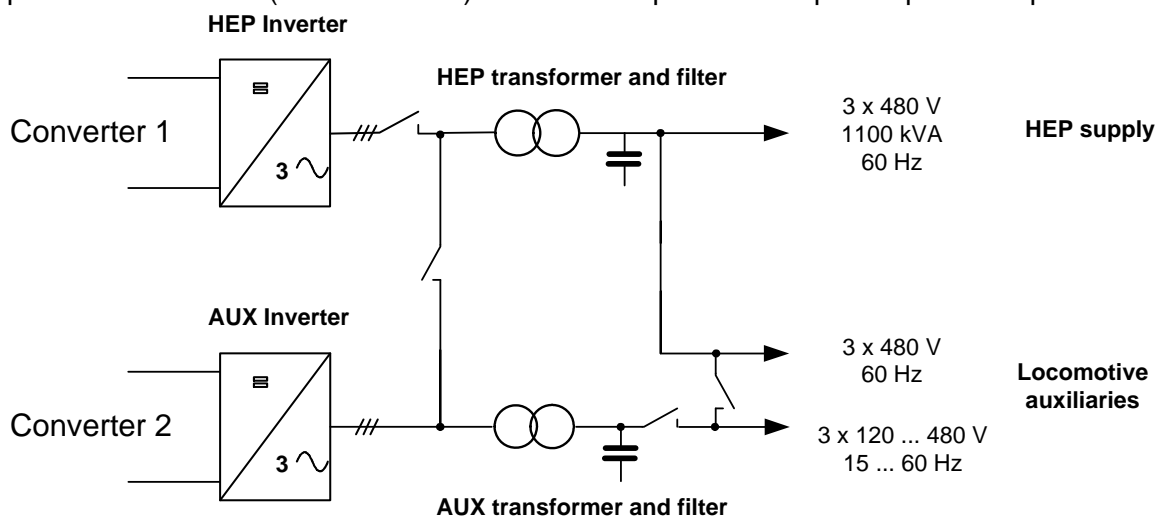

Figure – Schematic overview of HEP and AUX supply circuits

In case of failures either inverter may be isolated from the output and the full load will be supplied by the other inverter via an emergency cross-coupling contactor. One single source (480 V / 60 Hz) will be available in emergency mode to supply all loads including HEP with power.

Both the transformers and the inverter outputs are protected each by current monitoring and ground fault detection.

The HEP and the AUX power supply system may safely continue operation in case one single ground fault is detected.

Low Voltage Power Supply and Battery Charging

Locomotive Battery

The NiCd battery is installed in a dedicated compartment in the machine room in the rear part of the vehicle. This battery compartment is sealed against the machine room, ventilated and accessible from the outside only. This situation and its comfortable dimensions allow easy and convenient access to the battery for installation and maintenance.

The battery provides sufficient back-up power in the case of failed charging of battery and is designed to start the diesel engines. The battery network will have a minimum voltage of not less than 50 V and at the maximum of 87 V (while charging).

The expected battery back-up power and diesel start power will be available as long as the battery voltage will not drop below 50 V. The voltage is monitored by the vehicle control to take protective actions before a complete discharge of the battery, which also allows restarting the vehicle control after a protective shut down after a reasonable battery recovery time.

Only distilled water is needed for topping up, no electrolyte is used.

Brake

The compressor is a screw type with a capacity of 127 cfm (3,6 m³/min). It is electrically driven supplied by 480V/60Hz voltage. Hence nominal capacity is available independently from the Diesel engine speed. The main air reservoirs have a total capacity of 2 x 29.362 inch³ (2 x 480 l). An air Dryer Type G-W 994 manufactured by Graham White is provided.

The compressor is installed on top of the air brake rack. The rack also contains 2 air reservoirs, as well as the brake control equipment and other compressed air equipment like controls for pantograph, sanding and parking brake.

The brake control system is the FastBrake® Electronic Air Brake, which is the third generation of Wabtec's EPIC electronic locomotive braking system. It is a microprocessor-based electro-pneumatic braking system providing means for control of the train air brakes in locomotive applications. FastBrake® is made up of two major components: the Pneumatic Operating Unit (POU) and the Handle Controller Unit (HCU). The POU consists of four major portions:

1. Brake Pipe Control Portion (BP)
2. Brake Cylinder Control Portion (BCP)
3. Independent Application and Release Portion (IAR)
4. Power Supply Portion

FastBrake® has been developed to include Advanced Diagnostics to provide railroad personnel with step-by-step troubleshooting capabilities and recommended actions. FastBrake® can be further integrated with Distributed Power (DP) and Electronically-Controlled Pneumatic (ECP) braking applications. FastBrake® design configurations can support multiple pneumatic locomotive configurations as well as single or dual cab control.

Fuel Tank

The two (2) fuel tanks are fully integrated into the structure as important structural components. The tank main structure carries the traction rod pivot on the carbody side as well as the transformer mounting fixture. The principle of such an integrated design in combination with traction rods is proven on many Bombardier locomotives (e.g. class ME of Danish State Railways, class Di4 of Norwegian State Railways, Blue Tiger Locomotives, class DEM 2500 for Iraqi Republic Railways and more).

Each tank has a capacity of about 900 US gallons (3400 l).

The tanks are equipped with all fittings to fulfil the requirements, such as:

One fuel nozzle filler port on each side of the locomotive

Air vents

Fuel level indicator

Sufficient drains and openings for maintenance

Manually operated cut-off cocks in all return lines

Filler caps

Provisions are made to prevent fuel spillage in case of derailment, emergency braking, and rollover.

The lowest point of the fuel tanks is about 20" above top of rail, measured statically with fully worn wheels; this means that the fuel tanks are well protected in case of derailment. Danger of penetration by debris is minimized, as the tanks are protected by the trucks, the transformer, the full-width headstocks or front plates respectively.

Propulsion System

Overview

The propulsion system is divided into five main segments:

1. the high voltage equipment (components conducting and sensing the catenary current and voltage)
2. the main transformer

3. the power converter
4. the traction motors
5. the dynamic brake resistor

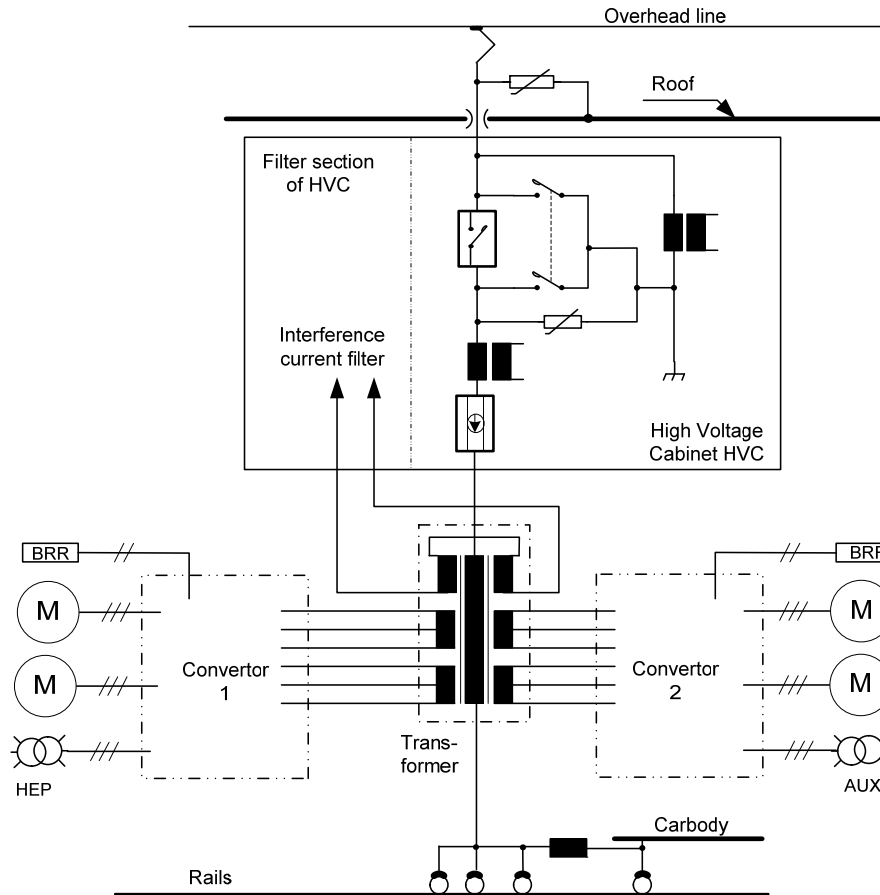

Figure – High voltage circuit in electric operation

Power Converter

The main converter of the Dual Powered locomotive is a modular state of the art IGBT voltage source converter of the Bombardier MITRAC® family. It is well proven in many locomotive applications such as TRAXX and high speed powerheads in Europe, heavy haul locomotives, ALP-46 locomotives of the latest generation and many more.

The cabinet houses two electrically independent converter circuits each of which supplying power to one bogie.

Each traction motor is supplied from a dedicated inverter with variable voltage and variable frequency.

Additional inverters are arranged in the converter cabinet for feeding the locomotive's auxiliary circuits and provide Head-End-Power to the

passenger coaches. Redundancy with respect to auxiliary and HEP supply is ensured by means of redundancy switches.

The line converters are designed as 4Q converters (4QC) and allow operation with a power factor equal to unity measured at pantograph level.

A brake chopper is installed to allow dissipation of the regenerated power in a braking resistor when the locomotive is operating in diesel mode. The braking chopper also acts as dynamic overvoltage protection for the converter in all operation modes.

Change over switches installed in the converter allow the commutation of the 4QC to the alternator terminals to supply the converter DC link with power in diesel mode operation.

IGBT semiconductors are mounted on standardized converter modules. The encapsulation of the IGBTs is of standard design, with enlarged creeping distances to cope with the operating voltage (HVIM = High-Voltage Industrial Module, refer to photo below). No snubber circuits are required with these semiconductors, thereby reducing the overall converter losses. The IGBTs are fixed to cooling plates (heat sinks). The internal electrical insulation between the semiconductor wafer and the base-plate allows the heat sink to be grounded, simplifying the general converter layout, and allowing usual distilled water as cooling fluid.



Figure –High-Voltage Industrial Module (HVIM)

One converter module (CMMM) consists of maximum 12 IGBTs, capacitors and cooling circuits. The CMMMs are mounted vertically into the converter cabinet and are accessible and mountable from the aisle of the locomotive. The capacitors in each module ensure that the loop inductance between semiconductors and dc link is minimized. The current transducers required for monitoring and protection purposes are directly fixed to the converter modules. Fitting the semi-conductors and the current

transducers on the same line replaceable unit ensures that the transducers will always be tested together with the semi-conductors they protect. The cooling plate contains the cooling liquid and is connected to the closed water cooling circuit. The circuit extracts about 90-95% of the losses generated in the converter, and transfers them to the heat exchanger located in the roof. A mixture of water and glycol (as anti-freeze protection) is used as cooling agent. The cooling circuit is monitored by pressure and temperature sensors. Pressure sensing will allow detection of a pump failure without delay.

The main converter components are shown in built-in status in the following figure. All the components subject to maintenance (mainly contactors) are arranged in a way that maintenance and tests may be done conveniently from the aisle.

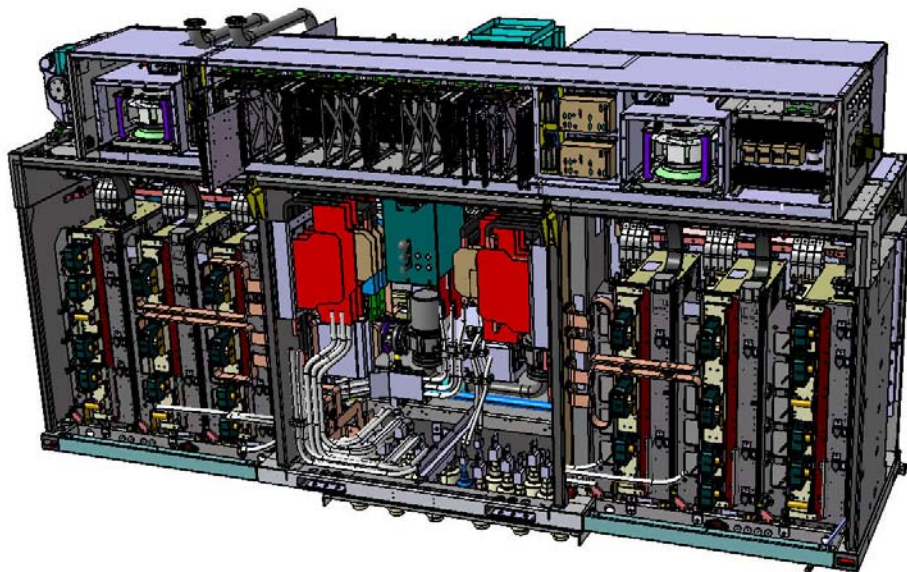

Figure – Schematic front view of the power converter

Converter Operation Under AC Overhead Line

The AC voltage at the terminals of the secondary windings of the main transformer is converted into a stabilized DC voltage by the 4Q line converter. The DC voltage is filtered by the DC link filter.

Converter Operation in Diesel Mode

The diesel engines power alternators of asynchronous three phase machine type. This results in several benefits such as total weight optimization and possibility to start the engine directly by the use of the alternator as a motor. Design and control of the alternator are comparable to the control of a traction motor in braking mode, where no additional active components are needed.

In the present case, some phase legs usually used in the 4QC as well as the respective control units are reconfigured to work as three-phase inverter:

1. in “generator” mode when the alternator is running and supplies power to the DC link.
2. in “motor” mode supplied by the DC link for starting the diesel engine.

For starting the diesel engine while the loco is parked and not connected to an electric overhead line the DC link is charged by means of a step up chopper from the battery. To limit the load to the battery only one diesel engine is started from the battery. Before starting the second diesel engine the battery is decoupled from the DC link, which is now fed by the running alternator and supplies energy to the other DC link to start the other engine. After successfully starting both engines the contactors between the DC links are opened to achieve a complete separation of the two traction chains.

When the loco is connected to an overhead line the DC links are charged through the 4QC. Before starting the diesel engines one 4QC is disconnected from the line and the contactor between the DC links is closed. The diesel engine not connected to the line fed DC link can now be started. After successful start the same procedure applies in alternative direction before finally opening the contactors between the DC links again.

Drive Unit

The drive is designed as a fully-suspended drive, type MITRAC® DR 3700 F, and comprises:

the air cooled, three phase asynchronous motor MITRAC® TM 3700F

stage helical spur gear box, MITRAC® GB 3700 I (including hollow shaft coupling)

The drive is based on the one used in ALP-46 locomotives, but totally suspended in the bogie. As a consequence the relative movements between the wheel shaft, the drive unit and the bogie frame are smaller, hence a reinforced (thicker) wheel-set shaft can be used in combination with the identical hollow shaft.

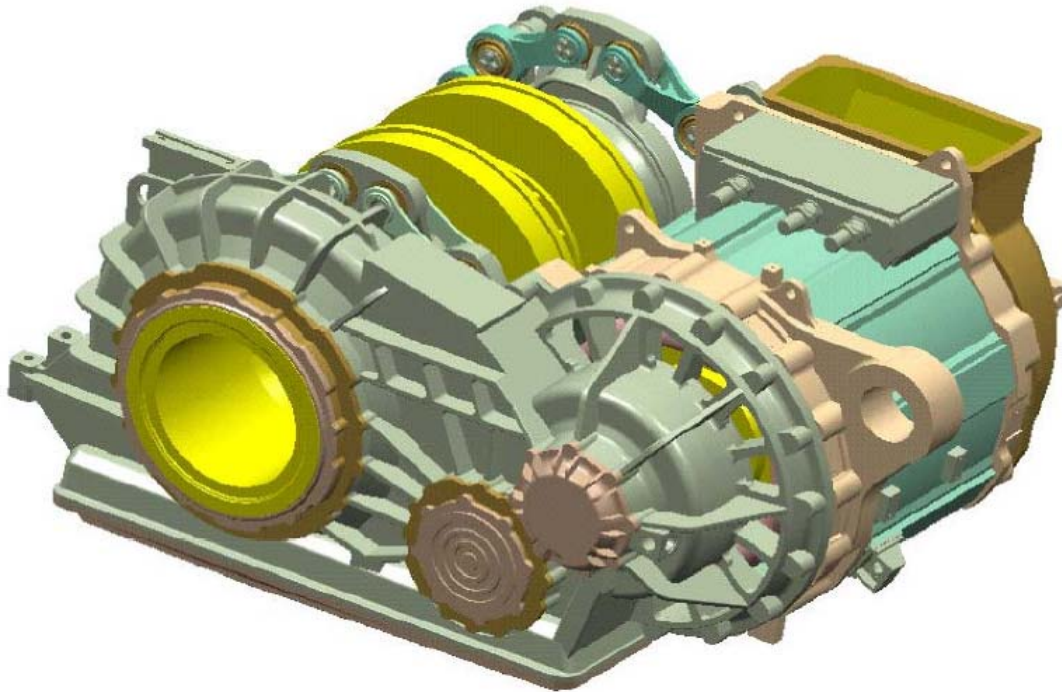

Figure 1 – Drive unit MITRAC DR 3700 F

Traction Motor

The traction motor is a 4 pole force-ventilated 3-phase-asynchronous motor with squirrel-cage rotor. It is flange-mounted directly to the gear housing, which serves as end shield for the D-side motor bearing.

The drive unit is suspended in the central cross member of the bogie by one elastomeric bearing and by two pendulums suspended in the headstock of the bogie. These pendulums are resiliently mounted to the gear housing and to a supporting arm fixed to the motor's N-side stator press ring respectively.

Prime Mover

The engine system architecture is characterized by the double engine arrangement (advantages of this system have been highlighted above). The two engines are located in two completely separate compartments, one on each side of the converter compartment.

Engine cooling systems are installed directly above each engine, the corresponding fuel tank directly below. By this arrangement, all piping is very short and easily accessible.

Diesel Engine Type

The installed engine is the Caterpillar 3512C HD, fulfilling EPA Tier 3 requirements for locomotives.

The nominal power output (shaft power) of each engine is 1567 kW, @ 1800 rpm, i.e. a total installed engine power of 3134 kW (4200 hp) in the locomotive. The engines can accelerate at about 100 rpm/s which is sufficient to not limit the total train acceleration.

It is an integrated unit with all auxiliaries like fluid filters, water and fuel pump mounted directly to the engine.

Braking Resistor

As explained above the regenerated braking power will primarily be fed back to the overhead line via the 4QC, apart from the power consumed onboard directly (locomotive auxiliaries and HEP). If regeneration into the overhead line is not possible (e.g. due to high line voltage or in diesel mode) the recovered power can be dissipated in the braking resistor up to the rated power of the resistor.

HVAC

The air conditioning unit with cooling, heating and integrated ventilation is of a compact design and installed in the centre of the operator's console.

Additional electric heating is provided on the cab rear wall. The control elements are located in the operating panel of the central desk console. The air-conditioning unit is independent containing all equipment needed for ventilation, heating, cooling and air dehumidification. It supplies the cab with treated circulating and outside air, so as to cool or heat it and also to provide the operator with the necessary amount of filtered fresh air. The circulating air is drawn out of the cab and led to the air-conditioning unit through openings in the front and in the centre console. The outside air is drawn in from beneath the cab and ducted vertically upwards to the air-conditioning unit. Fresh air for the cab is drawn in by the supply air fan located in the unit, provided that the outside air flap is open. It is mixed with circulating air from the cab. This mixed air then passes into the air distribution system through a filter, the air cooler (evaporator of the refrigeration system), the electrical heater and the supply air fan. The supply air is blown into the cab through a pre-distributor and to the outlet grille or through the blow-out nozzles in the foot niche.

Furthermore the HVAC allows a 'pure' air recirculation mode to keep the cab at a preset temperature with minimum energy consumption, either when the locomotive is operating in push mode, or during layover periods. For this purpose, recirculation flaps are provided which may be closed or opened via an electric control switch.

Monitoring and Diagnostics

C&C System Architecture

The Bombardier control and communication system architecture is based on the MITRAC® C&C system, a computerized, distributed system optimized for the application on electric traction vehicles and trains.

It consists of the following main computer systems.

Vehicle and Train Control unit (VTCU)

The VTCU, a standard component of vehicle communication and control for Bombardier locomotives, is used as C&C System, i.e. as main computer.

VTCU uses the standard vehicle bus MVB and communicates via a Gateway with the wired train bus WTB. One set of VTCU controls the whole vehicle. A second set of VTCU will contain the redundant vehicle control application and the redundant bus master application.

Basically the VTCU complies with the following functions:

Train control

Vehicle control

UIC Mapping Server

TCN Gateway

The gateway connects the train bus (WTB) and the vehicle bus (MVB), ensuring full transparency for data communication between vehicles in a train set. The gateway extracts the data that are sent on the vehicle bus for equipment in different vehicles of the train.

The Gateway supports train bus functions such as redundant WTB train lines, line fritting, standby mode and bus control. It also supports vehicle-bus functions such as line redundancy and bus control.

CONCLUSION

The combination of diesel-electric and electric traction in one single main line locomotive offers operators and passengers an increased comfort at system borders, because changing trains can be avoided. Operational concepts can be optimized.

Two high speed diesel engines are an innovative solution to optimize energy consumption and emissions. Modern high power converter technology offers a simple interface to connect the various energy sources.

Currently Dual Powered locomotives are developed for application in the North-American market, but based on the same concept innovative locomotives for European applications can be derived in the future, e.g. electric locomotives with a small diesel compartment for last

mile operation or diesel locomotives with multiple small engines. Such innovations combined with respective operation concepts will support the competitiveness of railways both in freight and passenger service.

REFERENCES

- Vitins, J. (2008). Modular locomotive family meets the needs of Europe's operators. *Railway Gazette International*, January 2008, 32-35
- Gerster, C., Skarpetowski, G., Sommer, H., Still, L. (2004). Advanced multi-system traction chain for locomotives and power heads. *EPE-PEMC 2004*. September 2004.
- Buscher, M., Koeck, F., Trotsch, P., Bikle, U. (2006). TRAXX: Integrated platform to increase the competitiveness of transport by rail. *ETR 9/2006*