

ONLINE OPTIMIZATION WITHIN COOPERATIVE SYSTEMS IN URBAN ROAD NETWORKS

UFFMANN, Anke; Technische Universität Braunschweig, a.uffmann@tu-bs.de

FRIEDRICH, Bernhard; Technische Universität Braunschweig, Friedrich@tu-bs.de

ABSTRACT

This paper shows how online optimization of traffic signal control is used within the cooperative system developed in the German research project KOLINE. This system aims at enhancing the traffic flow in order to achieve a reduction of delay and emission in urban road networks by exchanging information between traffic signals and approaching vehicles.

The main principle of the process is the generation of new signal programs for every intersection in intervals of 15 minutes. Therefore the traffic demand is determined by forecasting the detector values of the following optimization interval and estimating the OD matrix. Within the optimization process the global cycle length and the green times are calculated according to the estimated traffic demand. Afterwards offsets and progression speeds between intersections are optimized using a genetic algorithm. For evaluation of the fitness of every solution the Cell Transmission Model is used. Optimization parameters are the total number of stops or the total delay in order to improve traffic flow and the amount of emissions, taking into account that each stop produces a significant extra amount of emission compared to the consumption when traveling.

Keywords: cooperative system, online traffic signal program optimization, offset optimization, progression speed optimization, genetic algorithm, cell transmission model

I. INTRODUCTION

Necessary stops at traffic lights produce braking and reacceleration. This has a significant influence on the capacity of the urban road network and the emissions of the urban motorized traffic. Increasing traffic demand and ascending requirements of the directives limiting values of SO₂, NO₂, NO_x, and PM₁₀ (Council of the European Union, 1999) and environmental noise (Council of the European Union, 2002), urge operators of urban traffic infrastructure to act. An approved method for minimizing the total number of stops and hence for reducing the delay and emission in urban road networks consists in a good coordination of traffic lights (Rahka et. al. 2000, Friedrich et. al. 2008).

Progresses in wireless communication, GPS and sensor technology offer new alternatives for an optimized coordination. The chance of collecting precise traffic data and using car to infrastructure communication data (C2I-data) allow the design of cooperative systems in urban road networks. Plenty of projects in Germany (e.g. AKTIV, sim^{TD}) and Europe (e.g. CVIS, Safespot, COOPERS, Cosmo, Co-Cities) considered cooperative systems in their approaches to achieve advantages in traffic management. The cooperative system developed in the research project KOLINE mainly consists of two connected processes: (a) the adaption of traffic signal control, (b) the improvement of a vehicle's approach to intersections. The paper focuses on the first one. Details to the other process are described by Naumann and Bley (2012).

Different methods of traffic signal control have been developed in the last decades. The easiest form is the definition of fixed time signal programs, which ensure predictability of signal changes but is unable to flexibly react to current traffic demand. On the contrary, highly adaptive methods can handle the varying traffic demand in real-time, but complicate the forecasting of signal changes. To allow a real-time adaption on the current traffic demand combined with a certain reliability of the future signal timings, the approach of the presented online optimization method uses an adaptive traffic signal control system (ATCS). It consists of a dynamic adaption of fixed time signal programs in intervals of 15 minutes.

This duration, emanating from the optimization interval of 5 to 15 minutes in German online optimization methods in field like MOTION (Busch and Kruse 1993, Bielefeldt and Busch 1994, Kruse and Busch 2002) and BALANCE (Friedrich 1997, 2000a, 2000b), was regarded as a good compromise between a great flexibility to coordinate dense urban traffic and occurring disturbances in the network resulting from transitions between consecutive signal programs. Simultaneous optimizing of offsets and progression speeds between consecutive traffic signals increases the opportunities to achieve better coordination. Using C2I-data, the optimized progression speeds are directly transmitted to the cars passing the corresponding links. This information permits the vehicles to reduce or even prevent stops by adopting their speed to the recommended one.

Several existing ATCS have been expanded by genetic algorithm resulting in better solutions than former used algorithms and computation times quick enough for online implementation (Braun et al. 2008, Braun and Kemper 2011, Brilon et al. 2009). Therefore this method was also integrated in the presented online optimization process, described in detail in section IV. Approaches of using C2I-data in ATCS have also been made (Wu et al. 2007, Kurt and Peter 2006).

Section II gives a short description of the cooperative system within the research project KOLINE. In section III the online optimization process is discussed in detail. This process is a further development of the online control strategy from Pohlmann and Friedrich (2010a). Section IV presents the urban road network used for the optimization process and sketches some observed results. The paper closes with conclusions and future work which is expected to improve the demonstrated approach.

II. SYSTEM ARCHITECTURE

The main principle of the described cooperative system developed in the research project KOLINE consists in two complementary components: (a) the strategic adaption of traffic light

signals depending on the current traffic demand and (b) the vehicle's strategy in approaching a signalized intersection. These two components are in a first step opposed to each other, due to the fact that an adapted traffic signal program requires a new vehicle's strategy and vice versa. This makes a continuously feedback between traffic signals and vehicles indispensable. Figure 1 shows the architecture used for considering these requirements. It consists of three main components, which communicate to each other in real-time.

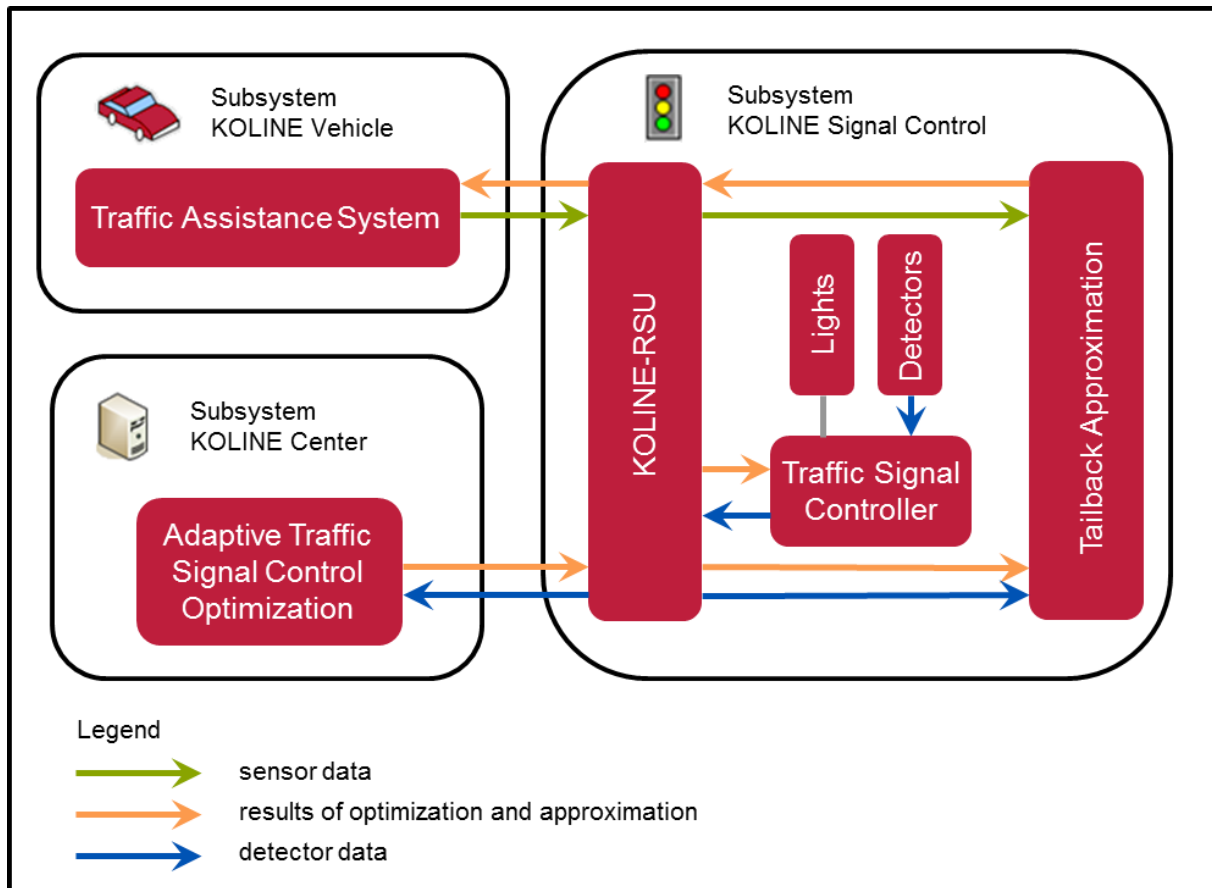

Figure 1 – Architecture of the KOLINE system

The subsystem KOLINE Vehicle is equipped with a traffic assistance system, which computes the optimal strategy for passing the intersection, which means preferably not to stop. For this calculation, topology information, future signal states and tailback information received by the subsystem KOLINE Signal Control are used. This strategy is implemented automatically by the vehicle without influence of the driver. The vehicle procures information about its speed and location to the signal control via wireless LAN (IEEE 802.11p).

The Adaptive Traffic Signal Control Optimization located in the subsystem KOLINE Center permanently generates signal programs for all traffic signal controllers of the network included in the optimization in intervals of 15 minutes. Based on aggregated traffic volumes measured by stationary detectors the optimization derives the traffic demand for the future interval using a method for estimation and forecasting, which is described in detail in Section IV. The resulting signal programs are coordinated to each other and sent to the traffic light controllers for execution.

The subsystem KOLINE Signal Control is connected to the signal program optimizer in the KOLINE Center via GPRS and to the vehicles via IEEE 802.11p. Located in the center of the

subsystem KOLINE Signal Control, the KOLINE-RSU serves as transceiver between the different functional components of the KOLINE system. It transmits the aggregated detector values from the traffic signal controller to the optimization and returns the optimized signal programs back to the controller. After checking for security conditions, the controller implements the signal program in case of acceptance and operates a predefined fixed time program otherwise. The KOLINE-RSU also sends the future signal states and the intersection's topology to the KOLINE Vehicles within the reception area. Information about the current traffic state at the intersections' accesses is sent as well. It is computed by the Tailback Approximation using vehicle related data, detector data and signal data. In the following, the paper will concentrate itself on the optimization component of the described KOLINE-system.

III. ONLINE OPTIMIZATION PROCESS

Overall system

As mentioned in the introduction, the presented online optimization process is based on the online control strategy by Pohlmann and Friedrich (2010a). Further enhancements mainly consist in additionally optimizing progression speeds between consecutive intersections and using the total number of stops instead of the total delay for minimization. However, the total delay is still available for optimization and is thus proposed as an alternative optimization target. The main difference between these two values is, that minimizing the number of stops prefers the generation of green waves, whereas minimizing the delay times only considers absolute lost times neglecting the number of stops producing them.

The presented optimization approach aims to optimize the traffic control system in a specified urban road network. Therefore the time is separated in consecutive time intervals with the length of 15 minutes. The general process is shown in Figure 2.

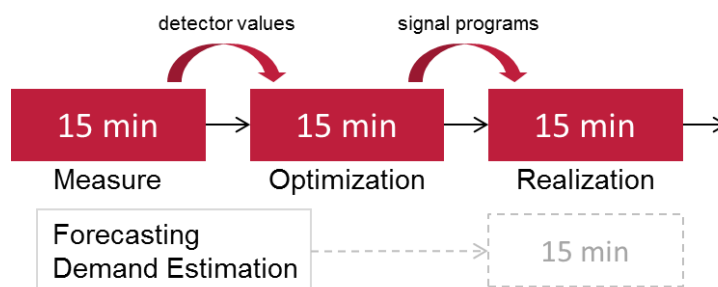

Figure 2 – Optimization Process

At the end of every interval, the optimization receives the detector values of the last 15 minutes as input for the new optimization process. The optimization process itself takes the next interval for calculating the new signal programs, which are realized in the following time window. Thus the demand for the optimized signal programs would be two intervals i.e. 30 minutes old, if the original values would be used. To prevent this problem, a forecasting process is added, which estimates the demand for the next but one interval, so that the optimization process can be applied for the desired interval.

The optimization approach itself is a dynamic adaption of fixed time signal programs, which consists of three different steps: (a) forecasting the detector values of the following optimization interval and estimating the OD matrix, (b) adaption of cycle times and stage durations, (c) optimization of offsets and progression speeds. The next paragraphs describe these steps one after the other.

Forecasting the detector values and estimation of OD matrix

The forecasting of the detector values is based on a pattern matching method proposed by Förster (2008) using current and reference space-time-patterns of detector counts. It has been slightly adapted and further developed by Pohlmann and Friedrich (2009a), who describe the actual procedure in detail. Therefore the paper limits itself to the basic principles of the process. Pohlmann and Friedrich (2009a) mention that for the ATCS thus not depending on special detector locations, directly detected turning flows are preferable because they contain the most precise constraints for the following traffic demand estimation. Anyway, section IV will sketch the problems occurring in oversaturated situations resulting from these stationary detectors close to the stop lines.

Basis of the pattern matching is a data set of historical detector values. During the generation of the data set, counts for every detector are collected over a certain time period (e.g. several weeks or month) and clustered into some relevant groups (e.g. different weekdays, Sundays, holidays), each containing the same number of days. For each group, the averages of the specific time interval for a specific detector are used as reference values for the detector and form altogether the belonging reference pattern.

Every time when a measurement of a specific interval T_0 has been completed, a two-dimensional pattern is generated out of the values of T_0 and the three preceding time intervals. The reference patterns are searched through for the most similar sub-pattern of the same length, identified by a preferably high correlation coefficient and a low mean squared error MSE. The reference values of the time interval to be predicted following this sub-pattern are taken as forecasted detector values with some modification according to the difference between the measured pattern and the reference sub-pattern.

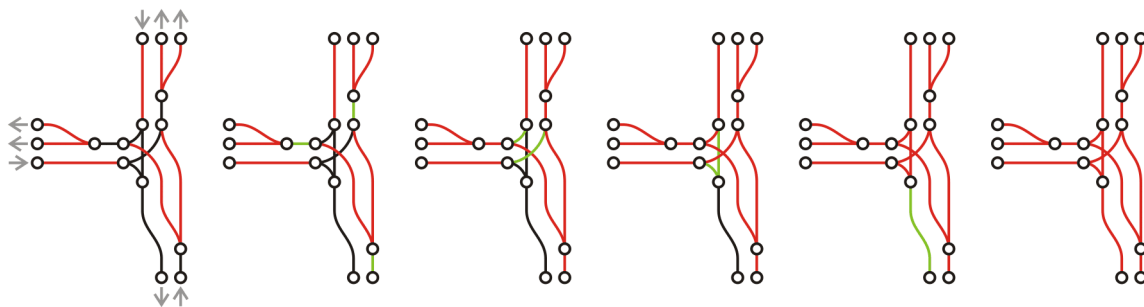

Figure 3 – derivation of detector values (see Pohlmann and Friedrich 2009b)

In general, not all links in the network are equipped with detectors, so that the described method can only be applied for the links with measured values. The optimization process' requirement of a known traffic demand for all links of the network makes an estimation of the unmeasured links indispensable. Following the information minimization (IM) model presented by van Zuylen and Willumsen (1980), several forecasted detector values are used

as constraints to estimate the missing values. To increase the correctness of the forecasted values and reduce the amount of estimated counts, as many as possible are derived out of the fixed detector values. This derivation process is shown in **Fehler! Verweisquelle konnte nicht gefunden werden.**

The links with already known values are displayed in red whereas the black ones represent the others. On the left side the original state is depicted. The arrows at the network borders show the direction of the according links. Aside the different steps of the derivation are presented. In each step, for all nodes with only one unknown adjacent link, the missing value is derived from the others by addition or subtraction, depending on the direction of the traffic flow, using the following common flow conservation formula:

$$\sum_{i=1}^n x_i = \sum_{k=1}^m x_k ,$$

where x_i are the detector values of the incoming and x_k the values of the outgoing links, respectively. These links are displayed in green. The process comes to an end, when no more values can be achieved. For implementation reasons, this basic idea has been realized with a simple iterative algorithm described by Pohlmann and Friedrich (2009b) requiring all nodes of the graph having either one single input or one single output link. This type of graph can be obtained by splitting nodes with multiple input and output links into two nodes and connecting them by a single link in flow direction. More details can be found in Pohlmann and Friedrich (2009b).

Since inconsistencies of the measured detector values cannot be excluded, another method proposed by Zuylen and Branston (1982) balancing the inconsistent traffic flows resulting in a maximum likelihood estimate of consistent link volumes is applied afterwards.

In general, the derivation process is not able to complete the detector values for all missing links of the network. Therefore the remaining values have to be achieved by OD matrix estimation and a subsequent assignment. Starting with a unit matrix, an alternate sequence of traffic assignment and matrix estimation is iterated until convergence. The matrix and the assignments of the last step are used for determination of estimated flows on each predefined route and the links of the network. Again, details can be found in Pohlmann and Friedrich (2009b).

Adaption of cycle times and stage durations

Based on the estimated traffic volumes, the optimal cycle times and stage durations can be calculated in two steps: (a) determination of local optimal cycle times and stage durations and (b) determination of a global optimal cycle time and the corresponding stage durations. The stages and the stage sequence used for the overall process have to be predefined offline.

The first step is split in two parts. Primarily local optimal cycle times and stage durations for the different signalized intersections are calculated with negligence of minimum stage durations. For the adjustment of cycle length, between two formulas can be chosen. One is the Webster formula (Webster, 1958) only suitable for isolated intersections, so the other saturation based formula should be selected for coordinated roads and networks.

Therefore, the following well-known formulas are applied to determine the different cycle length t_c and stage durations $t_{g,i}$ for all stages i :

$$t_c = \frac{T_{IG}}{1 - B/x}$$
$$t_{g,i} = \frac{b_i}{B} \cdot (t_c - T_{IG})$$

where T_{IG} = sum of intergreen times of all stage changes,
 $b_i = v_i / s_i$ = relevant ratio of flow to saturation flow of stage i ,
 B = sum of b_i ,
 x = desired degree of saturation.

In case of violations of minimum stage durations, the cycle length is corrected upwards using the following formula:

$$t_c = \frac{T_{IG} + T_{g,min}}{1 - B/x}$$

where $T_{g,min}$ = sum of minimum green times of the stages violating the minimum green time
 B' = sum of b_i of all stages exceeding minimum green time.

To allow a coordination of the signalized junctions, the global optimal solutions are determined in a second step. Therefor the maximal local cycle time of the different signalized junctions is used system-wide. For all junctions with a lower local optimum, the stage durations have to be adapted to the new cycle time. The remaining seconds are distributed to the traffic streams depending on their traffic volume.

Optimization of offsets and progression speeds

To achieve a good coordination of traffic signalized intersections in urban road networks with predefined signal programs several possibilities are available. In this approach, two of them are especially accentuated: the optimization of (a) offsets and (b) progression speeds between consecutive signalized intersections. The offset optimization aims at shifting the green times to allow the vehicles passing several intersections in a row without stopping. For offset optimization, a fixed free flow speed between adjacent signalized intersections is used to determine the travel time needed by a vehicle to cover the distance. The other possibility, the optimization of progression speeds, normally assumes given offsets and tries to change the speed of the vehicles in order to adapt the vehicle travel time to the time difference between the corresponding green times. The speed used for the coordination between consecutive signalized intersections will be called as progression speed for this connecting section.

In Figure 4 the relevance of offsets and progression speeds is demonstrated. At the bottom of the figure a street with two consecutive signalized intersections is displayed. The time-distance-diagram above shows the signal changings and the trajectories of some vehicles passing the distance without stopping. The progression speed determines the slope of the trajectories. The offset depicted on the right describes the time difference between the

corresponding red times, but can also be defined as difference between the corresponding green times.

The approach of this paper combines these two possibilities, so offsets and progression speeds are optimized together. This allows a higher flexibility and a greater optimization potential. The optimization process searches for an optimal combination of offsets and progression speeds, which minimizes the objective function. As optimization target, the total number of stops or the total delays can be chosen.

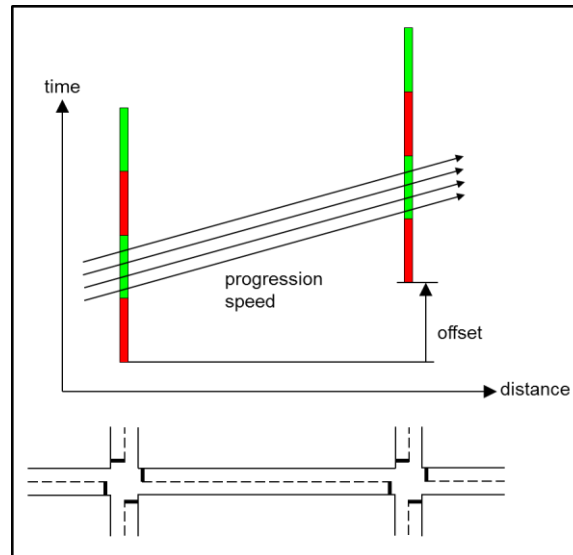

Figure 4 – Offset and Progression Speed

As mentioned in section I, a genetic algorithm is used for optimization. For implementation, the open source Java Genetic Algorithms and Genetic Programming Package (JGAP) provided by Meffert et al. (2009) has been applied. The principle of the genetic algorithm is adopted from evolutionary theory and consists in continuously generating new solutions sets out of a current set by selecting the best, recombining them and randomly introducing mutations to escape local optima. A single solution of the presented online optimization process consists of two types of integer value: (a) an offset value for every intersection included in the optimization in the range of zero to $t_c - 1$ and (b) a progression speed value for every section connecting two signalized intersections considered in the optimization, currently in the range of 30 to 50 km/h for the use in urban road networks. As stop criterion, the maximal computation time corresponding to the length of the optimization intervals is used.

For fitness evaluation, the Cell Transmission Model (CTM), first proposed by Daganzo (1994, 1995) enhanced by Pohlmann and Friedrich (2010b), is applied. Thus initially demonstrated for highway applications, modeling of urban traffic is also possible. It is a space and time discrete traffic flow model. Time discretization is realized by dividing the simulation time in equal steps, e.g. seconds in the presented approach. Each link is split in cells, the length corresponding to the maximal distance covered by a vehicle in one simulation step to prevent the vehicles passing more than one cell at once. Thus the length of the cells is dependent on the progression speed of the corresponding link, which even results in a varying number of cells while changing the progression speed. Therefore the cells of a link have to be recalculated whenever the speed is changed during the optimization process.

Every cell can represent either a single lane or a couple of lanes. In this approach, all lanes in intersection areas are represented by single cells, whereas only one cell per cross section is used on the connecting roads, in general containing more than one lane. This results in a macroscopic model approach with different levels of abstraction.

In each simulation step the flow passing from one cell to the other is calculated using the model equations of Daganzo (1994). Basically, the inflow and the outflow of each cell are computed and the number of current vehicles in each cell is updated afterwards. Blocking of traffic signals, capacity constraints and priority rules in case of several preceding cells are respected. The simulation of traffic flows is an abstraction of real traffic, because no single vehicles can be modeled. This fact results normally in non-integral cell occupancies compared to a microscopic simulation model.

The aim to minimize the number of stops instead of the delays using the CTM requires a further adaption of the model described by Daganzo (1994). This is realized by the following method: In every simulation step where the outflow of certain cells equals zero, which means downstream is blocked by a red traffic light, the occupancies in these cells in the last simulation step are added to gain the recently occurred stops. These values are summed up during the whole simulation process, which finally results in the total number of stops.

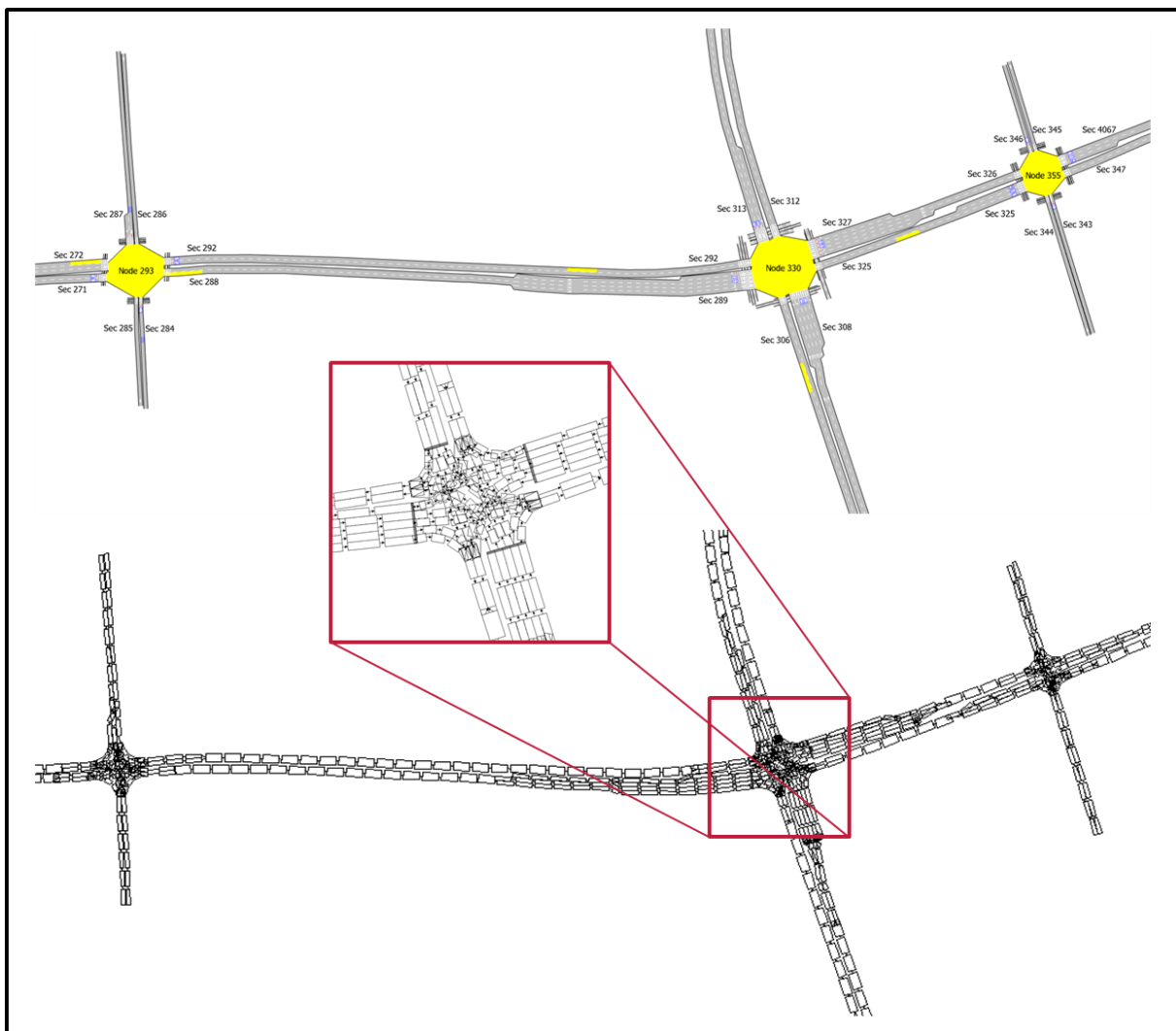

Figure 5 – Comparison of microscopic Aimsun 6.1.5 and CTM network representation

Figure 5 shows a network consisting of three intersections represented in two different models: the microscopic model generated with Aimsun 6.1.5 and the macroscopic CTM. To profit of the great amount of statistical values calculated by Aimsun, this program was used for constructing a virtual test site for the evaluation of the online optimization process (further details can be found in section IV).

IV. RESULTS

For the evaluation of the optimization process, the subsystem KOLINE Center of the KOLINE architecture is tested separately from the other two subsystems. The tests and evaluation are performed using the virtual test environment, which was provided by the microscopic simulation model Aimsun 6.1.5. During the online optimization process, the two systems exchange information as depicted in Figure 6.

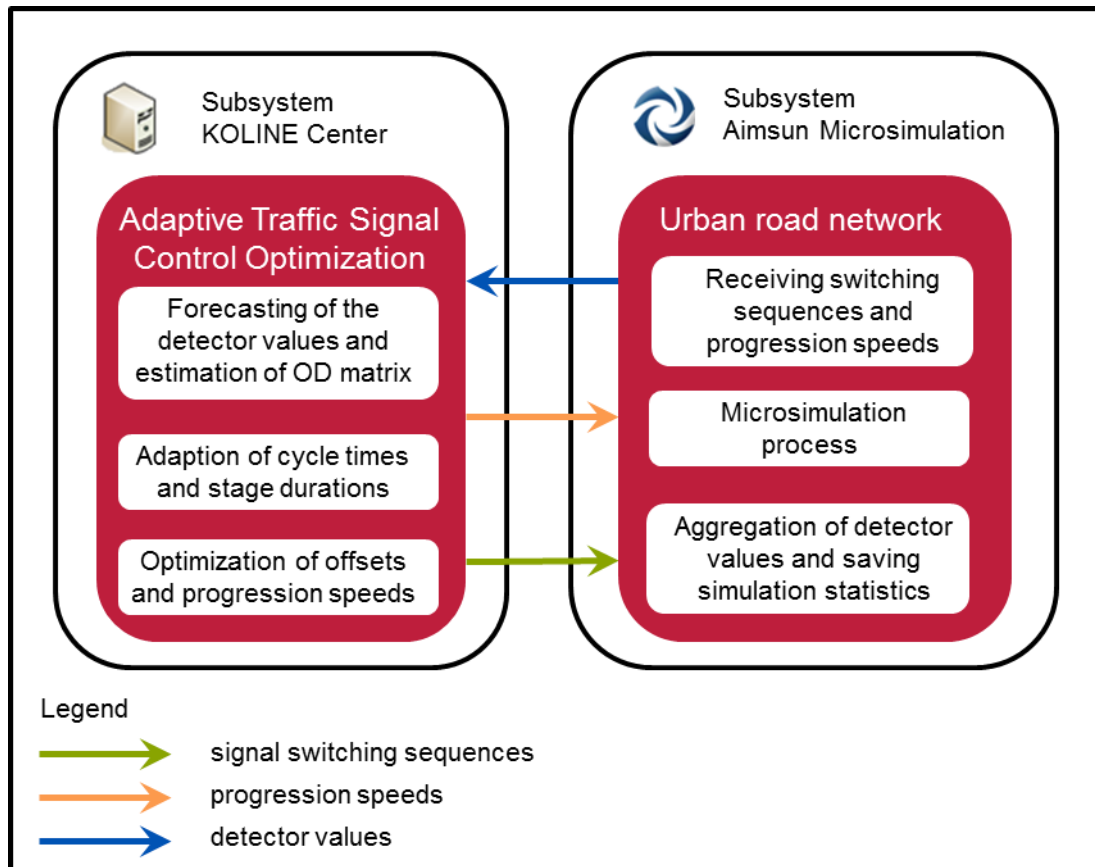

Figure 6 – System design for the evaluation of the Online Optimization Process

At the end of every optimization process, the optimization sends the calculated signal switching sequences and the optimal progression speeds to Aimsun, which uses the information to simulate the traffic flow in the corresponding time interval. The signal switching sequences are directly passed to the signal controllers for execution, whereas the progression speeds are communicated to all vehicles entering the belonging sections of the network. While simulating, Aimsun collects detector values of the stationary detectors within the network and other statistical information in a database. The detector values are

additionally prepared in an aggregated form and sent to the optimization process, which uses them as an input for the next optimization process consisting of the three parts described in detail in section IV.

This process is tested for a small urban road network in Braunschweig, Germany, consisting of three signalized intersections to be optimized and four signalized intersection at the borders with given signal programs. Located in the north east of the city center, the test site is characterized by two main roads crossing at the middle intersection. The most frequented routes run from west to south in both directions. For the simulation, the real traffic demand is used. The demand values were obtained through a traffic survey for the afternoon rush hour and by the values of additional continuous counts to achieve a day time series. During this traffic survey, traffic flow volumes and turning percentages have been considered. The Cell Transmission Model used for the optimization only contains passenger car traffic, so the not motorized traffic is neglected for the evaluation. The whole network is shown in Figure 7.

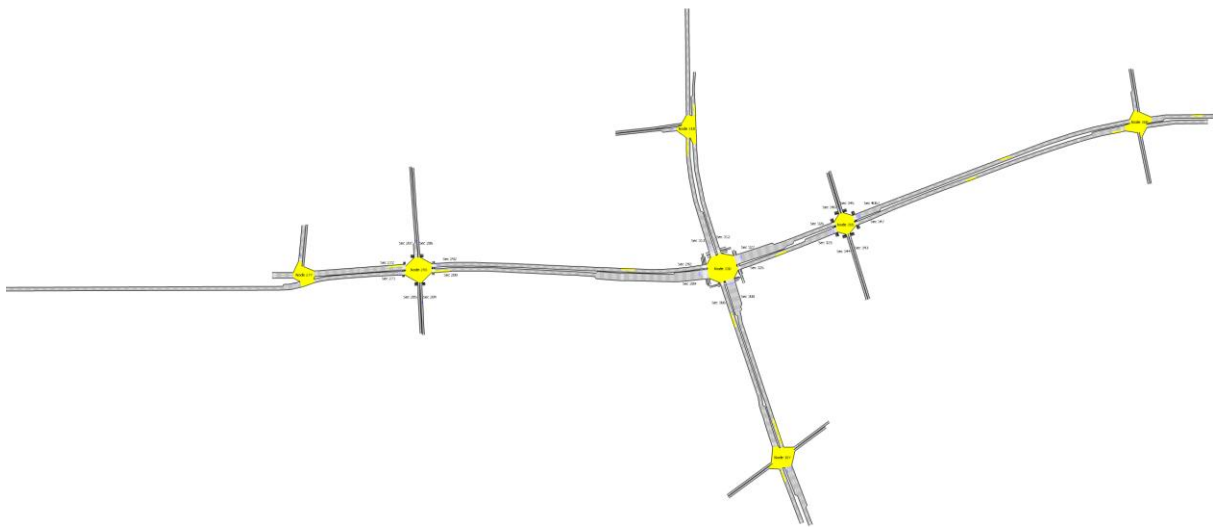

Figure 7 – Network for testing the optimization

Observations of the simulation using the online optimization process showed that it is unable to handle oversaturated situations how they occur in the real test site during the rush hours. This is caused by the method used for the forecasting process of the detector values, mentioned in section IV. For the determination of future traffic demand, the values of stationary detectors close to the stop lines of the intersections are used to gain information about the turning movements of the vehicles. In undersaturated situations, the measured values are equivalent to the demand of the corresponding approach lane to the intersection. In case of oversaturation, tailbacks can't be recognized by these detectors, which systematically lead to an underestimation of especially bonded traffic flows. In consequence, the optimization assigns less green time to these traffic flows resulting in increasing tailbacks in the next interval. Therefore even small tailbacks can produce big problems of capacity and may cause a total collapse of the network or selected traffic flows.

Reducing the traffic demand decreases the probability of occurrence for this effect, but future work should be done to enable the CTM for situations of oversaturation. E. g. other detector locations or additional methodical improvements like the integration of tailback information

are expected to result in a better performance of the control method in the future development.

V. CONCLUSIONS AND FUTURE WORKS

The presented online optimization method promises a potential for the reduction of stops in urban road networks for undersaturated situations. Minimizing the number of stops results in less emissions of the motorized traffic and less disruptions of the traffic flow. Handling oversaturated situations is still a problem of the approach, but several methodical improvements are imaginable to prevent it. Though using detectors that are located further away from the stop lines leads to a loss of turning information, it could be possible to combine them with detectors close to the stop lines or even consider new traffic information like C2X-data as virtual detectors for the optimization. Another option consists in the integration of tailback information in the Cell Transmission Model to reduce the deviations in case of oversaturation.

VI. ACKNOWLEDGEMENTS

The cooperative system presented in this paper was developed within the project KOLINE (www.koline.info) – Cooperative and Optimized Traffic Signal Control in Urban Networks. Partners in the project were German Aerospace Center (DLR), Institut für Automation und Kommunikation Magdeburg, Technische Universität Braunschweig (Institute of Transportation and Urban Engineering, Institute of Control Engineering), Transver GmbH, and Volkswagen AG.

REFERENCES

- Bielefeldt, C. Busch, K. (1994): MOTION – A New On-line Traffic Signal Network Control System. Proceedings of the Seventh International Conference on Road Traffic Monitoring and Control, London, UK, April 26-28
- Braun, R., C. Kemper and F. Weichenmeier (2008). TRAVOLUTION – Adaptive Urban Traffic Signal Control with an Evolutionary Algorithm. In: Proc. Of the 4th International Symposium Networks for Mobility, Stuttgart, Germany
- Braun, R., C. Kemper (2011). An evolutionary algorithm for network-wide real-time optimization of traffic signal control. In: IEEE Forum on Integrated and Sustainable Transportation Systems (FISTS), pp. 207-214, Vienna, Austria
- Busch, F., Kruse, G. (1993): MOTION – Ein neues Verfahren für die städtische Lichtsignalsteuerung und seine Erprobung im Rahmen des EG-Programms ATT. Proceedings of Heureka '93, Karlsruhe, Germany
- Brilon, W., T. Wietholt, A. Pott and U. Zelke (2009). Adaptive koordinierte Signalsteuerungen in Münster. In: Straßenverkehrstechnik, Kirschbaumverlag, Vol. 9, pp. 565-573

- Council of the European Union (1999). Directive 1999/30/EC relating to limit values for sulphur dioxide, nitrogen dioxide and oxides of nitrogen, particulate matter and lead in ambient air. April 22 1999.
- Council of the European Union (2002). Directive 1002/49/EC relating to the assessment and management of environmental noise. June 25 2002.
- Daganzo, C. (1994). The Cell Transmission Model: A dynamic Representation of Highway Traffic consistent with the Hydronamic Theory. In: *Transportation Research B* 28 (4), 169-287
- Daganzo, C. (1995). The Cell Transmission Model, Part II: Network Traffic. In: *Transportation Research B* 29 (2), 79-93
- Förster, G. (2008). Kurzfristprognose auf Basis von Raum-Zeit-Mustern. In: *Optimierung in Verkehr und Transport* (Forschungsgesellschaft für Straßen- und Verkehrswesen, ed.), HEUREKA `08, FGSV Verlag, Köln, Germany
- Friedrich, B. (1997): Ein verkehrsadaptives Verfahren zur Steuerung von Lichtsignalanlagen. Doctoral thesis at the Chair of Traffic Engineering and Planning, Technische Universität München, München, Germany
- Friedrich, B. (2000a): Steuerung von Lichtsignalanlagen: BALANCE – ein neuer Ansatz. In: *Straßenverkehrstechnik* 7/2000, pp. 321-328
- Friedrich, B. (2000b): Models for Adaptive Urban Traffic Control. In: *Proceedings of the 8th Meeting of the Euro Working Group on Transportation*, Rome, Italy, September 11-14
- Friedrich, B., T. Schüler and J. Rohde (2008). Emissions- und Kraftstoffreduzierung im Stadtverkehr durch innovative Verkehrslenkungsmaßnahmen. Schlussbericht zum von der Deutschen Bundesstiftung Umwelt geförderten Forschungsvorhaben, Osnabrück, Germany
- Kruse, G., Busch, F. (2002): MOTION for SITRAFFIC – Optimierung der Lichtsignalsteuerung im Einsatz. *Proceedings of Heureka '02*, Karlsruhe, Germany
- Kurt, D. and S. Peter (2006). Traffic intersections of the future. In: *Proc. of the 21st National Conference on Artificial Intelligence*, Boston, USA.
- Lo, H. K. (1999). A novel traffic signal control formulation. In: *Transportation Research A* 33, 433-448
- Lo, H. K. (2001). A Cell-Based Traffic Control Formulation: Strategies and Benefits of Dynamic Timing Plans. In: *Transportation Science* 35 (2), 148-164
- Meffert, K. et al. (2009). JGAP – Java Genetic Algorithm and Genetic Programming Package. URL: <http://jgap.sf.net>
- Naumann, S. and O. Bley (2012). A System for Traffic Light Control Optimisation and Automated Vehicle Guidance Using the V2X Communication Technology. *Archives of Transport Systems Telematics*, September, 3-7. ISSN 1899-8208
- Pohlmann, T. and B. Friedrich (2009a). Combined Short-Term Forecasting and Traffic Demand Estimation for Online Control Strategies. In: *Proceedings XIII Euro Working Group on Transport Meeting*, Padua, Italy
- Pohlmann, T. and B. Friedrich (2009b). Short Term Estimation of OD Matrices and Traffic Streams in Urban Networks. In: *Proceedings mobil.TUM 2009 International Scientific Conference on Mobility and Transport*, Munich, Germany

- Pohlmann, T. and B. Friedrich (2010a). A New Online Control Strategy for Signalized Urban Sub-Networks. In: Proceedings of the 12th World Conference on Transportation Research (WCTR 2010), 11-15 July 2010, Lisbon, Portugal
- Pohlmann, T. and B. Friedrich (2010b). Online Control of Signalized Networks using the Cell Transmission Model. In: Proceedings of the 13th International IEEE Conference on Intelligent Transportation Systems (ITSC 2010), Madeira, Portugal
- Rahka, H., M. Van Aerde, K. Ahn and A. A. Trani (2000). Requirements for Evaluating Traffic Signal control Impacts on Energy and Emission based on the Instantaneous Speed and Acceleration Measurements. In: Transportation Research Record, Vol. 1738(1), pp. 56-67
- van Zuylen, H.J. and L.G. Willumsen (1980). The Most Likely Trip Matrix Estimated from Traffic Counts. In: Transportation Research B, Vol. 14, pp. 281-293
- van Zuylen, H. J. and D.M. Branston (1982). Consistent Link Flow Estimation From Counts. In: Transportation Research B, Vol. 16 (6), pp. 473-476
- Webster, F. V. (1958). Traffic Signal Settings. Road Research Technical Paper Vol. 39, Department of Scientific and Industrial Research, Road Research Laboratory, London, UK
- Wu, J., A. Abbas-Turki, and A. Correia (2007). Discrete Intersection Signal Control. In: Proc. Of the IEEE International Conference on Service Operations and Logistics and Informatics, Philadelphia, USA